

## Ball Lock® T-Columns

- Class 40 Cast Iron
- Also available in Aluminum
- Ball Lock® Receiver Bushings and Liner Bushings installed
- Perpendicularity is 0.001" per foot

### Custom Sizes Available with or without Ball Lock®

We are able to quote you on your special requirement with or without the Ball Lock® Mounting System. Call 1-877-426-2504 for design specification information.

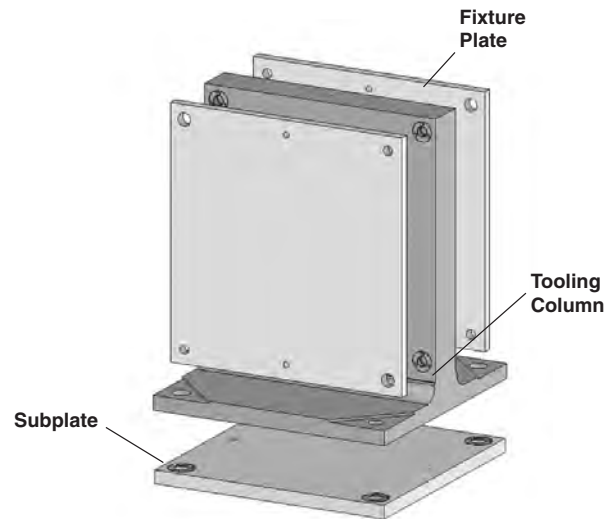

### Cast Iron T-Columns With Ball Lock® Receiver Bushings Installed

See page 15 for Fixture Plates and Subplates

Pallet Size (mm)	Part Number	C (in)	D (in)	E (in)	F (in)	G (in)	H (in)	I (in)	J (in)	K (in)	L (in)	M (in)	N (in)	O (mm)	P (mm)	Wt. (lbs)
400	69101	16.375	1	15.75	15.75	14	14	14	14	4	19.875	4.875	3.5	20	20	425
400	69102	16.375	1	15.75	15.75	12	12	12	12	4	19.875	5.875	3.5	20	20	425
500	69111	22.375	1	19.68	19.68	19	17	17	17	4.7	25.875	5.375	3.5	25	25	700
500	69112	22.375	1	19.68	19.68	17	17	17	17	4.7	25.875	7.375	3.5	25	25	700
630	69121	22.375	1.5	25	25	23	22	21	21	4	29.875	5.375	3.5	35	25	1125

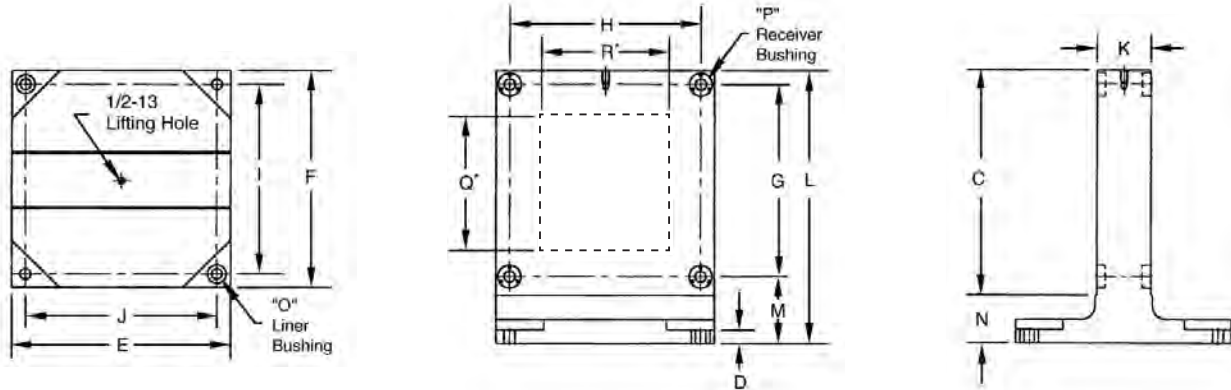

\*Note: Window sections are also available on T-Columns. Specify window size and location (Q and R Dimensions).

### Corresponding Fixture Plates, Subplates and Ball Lock® Shanks

Pallet Size (mm)	T-Column Part Number	Aluminum Fixture Plate Part Number	Steel Fixture Plate Part Number	Fixture Plate Size	Fixture Plate Ball Lock® Shank Part Number	Shank Size	Subplate Part Number	Subplate Ball Lock® Shank Part Number	Shank Size
400	69101	28717	28817	16 x 16	49601	20mm x 3/4	49102	49602	20mm x 1
400	69102	28715	28815	16 x 16	49601	20mm x 3/4	49101	49602	20mm x 1
500	69111	28745	28845	20 x 22	49612	25mm x 1	49103	49612	25mm x 1
500	69112	28727	28827	20 x 20	49612	25mm x 1	49103	49612	25mm x 1
630	69121	28746	28846	25 x 26	49612	25mm x 1	49104	49633	35mm x 1-1/2

Use Hoist Ring 23411, see Lifting Solutions Catalog or Master Catalog for lifting and handling – Order separately.

### Engineering Changes

Product improvement is a continuing process at Jergens. Specifications and engineering data are subject to change after publishing. Contact Jergens Technical Sales Department to verify any dimensions or specifications.